Thermal Care

7720 N. Lehigh Avenue
Niles, IL 60714-3491

Phone (847) 966-2260

Fax (847) 966-9358

E-mail info@thermalcare.com

Website www.thermalcare.com

Customer Service

Phone (847) 966-2636

Fax (847) 966-2906

Parts

Phone (847) 966-8560

Fax (847) 966-6065

Operation and Installation Manual

PSF Series

Filtration System

TABLE OF CONTENTS

	Page No.
Foreword	1
Pre-Installation	2
Receiving Inspection	2
Inspection Chart, Table 1	2
Rigging, Handling & Locating Equipment Components, Diagram 1	3
Installation	4
Piping	4
Connection Sizes, Table 2	4
Filter Flow Rates, Table 3	5
Actuator Requirements	6
Loading the Filter Media	6
Media Quantities, Table 4	6
Wiring	7
Single Phase Electrical Requirements, Table 5	7
Three Phase Electrical Requirements, Table 6	8
Operation	10
Water Treatment	10
Start-Up	12
24 Hour/7 Day Clock	12
24 Hour/7 Day Clock, Diagram 2	12
Initial and Seasonal Start-Up	13
Preventive Maintenance	15
Cold Weather Operation	15
Seasonal Shutdown	15
Maintenance Procedures	16
Safety Precautions	18
Operation & Maintenance Schedule, Table 7	19
Diagrams	
Parts Assembly, Diagram 3	20
Pump Parts Assembly, Diagram 4	21

FOREWORD

The intent of this manual is to serve as a guide for placing a Thermal Care PSF Filtration System in service, and operating and maintaining it properly. This manual will be supplemented as required to accommodate any special items which may have been provided for a specific application. *The written information contained in this manual, as well as various drawings, are intended to be general in nature.* The schematics included in this manual are typical only. Thermal Care strives to maintain an accurate record of all equipment during the course of its useful life. While every effort is made to standardize the design features of the unit, the various options may make it necessary to rearrange some of the components; therefore, some of the general drawings in this manual may differ from your specific unit.

Specific references to current applicable codes, ordinances, and other local laws pertaining to the use and operation of this equipment are avoided due to their ever changing nature. There is no substitute for common sense and good operating practices when placing any mechanical equipment into operation. **We encourage all personnel to familiarize themselves with this manual's contents. Failure to do so may unnecessarily prolong equipment down time.**

It is recommended that good piping practices are followed and that the information in this manual is adhered to. Thermal Care cannot be held responsible for liabilities created by substandard piping methods and installation practices external to the unit. It is important that maintenance personnel review this manual carefully, including the safety precautions and warnings prior to performing any repairs or maintenance on the PSF Filtration System.

We trust your Thermal Care equipment will have a long and useful life. If you should have any questions, please contact our Customer Service Department at (847) 966-2636 or by fax at (847) 966-2906, specifying the serial number and model number of the unit as indicated on the nameplate.

PRE-INSTALLATION

Receiving Inspection

Each unit is skid mounted and either boxed or crated prior to shipment. Before accepting delivery, check the overall equipment condition for any visible damage. If damage is evident, it should be properly documented on the delivery receipt. Shipping damage is the responsibility of the carrier. In order to expedite payment for damages, it is important that proper procedures be followed and records kept. Photographs of damaged equipment are excellent for your records.

Once the unit is removed from the box or crate, it should be inspected for hidden damage. Check for broken lines, damaged controls, or any other major component torn loose from its mounting point. Table 1 shows the parts which should be inspected when the unit is unpacked.

**Table 1
Inspection Chart**

PSF Series Parts
Filter Tank Valves & Linkage Filter Interconnecting Piping
Pump Pre-Strainer, Tank & Basket Pump NEMA-3R Box (Automatic Units Only)
Filter Skid Pressure Gauge, Air Relief Valves & Tees Media (Shipped Loose)

Note: Any sign of damage should be recorded and a claim filed immediately with the shipping company. Thermal Care will provide assistance in preparation and filing of your claims, including arranging for an estimate and quotation on repairs; however, filing the claim is the responsibility of the receiving party.

Rigging, Handling, and Locating Equipment

Proper rigging methods must be followed to prevent damage to components. Avoid impact loading caused by sudden jerking when lifting or lowering the unit. Use pads where abrasive surface contact is anticipated. The skid supporting the unit can be used for positioning the unit with a fork lift. If these units are lifted with an overhead crane, lifting straps must be located below the filter skid and should not come in contact with the filter components.

Diagram 1
Components

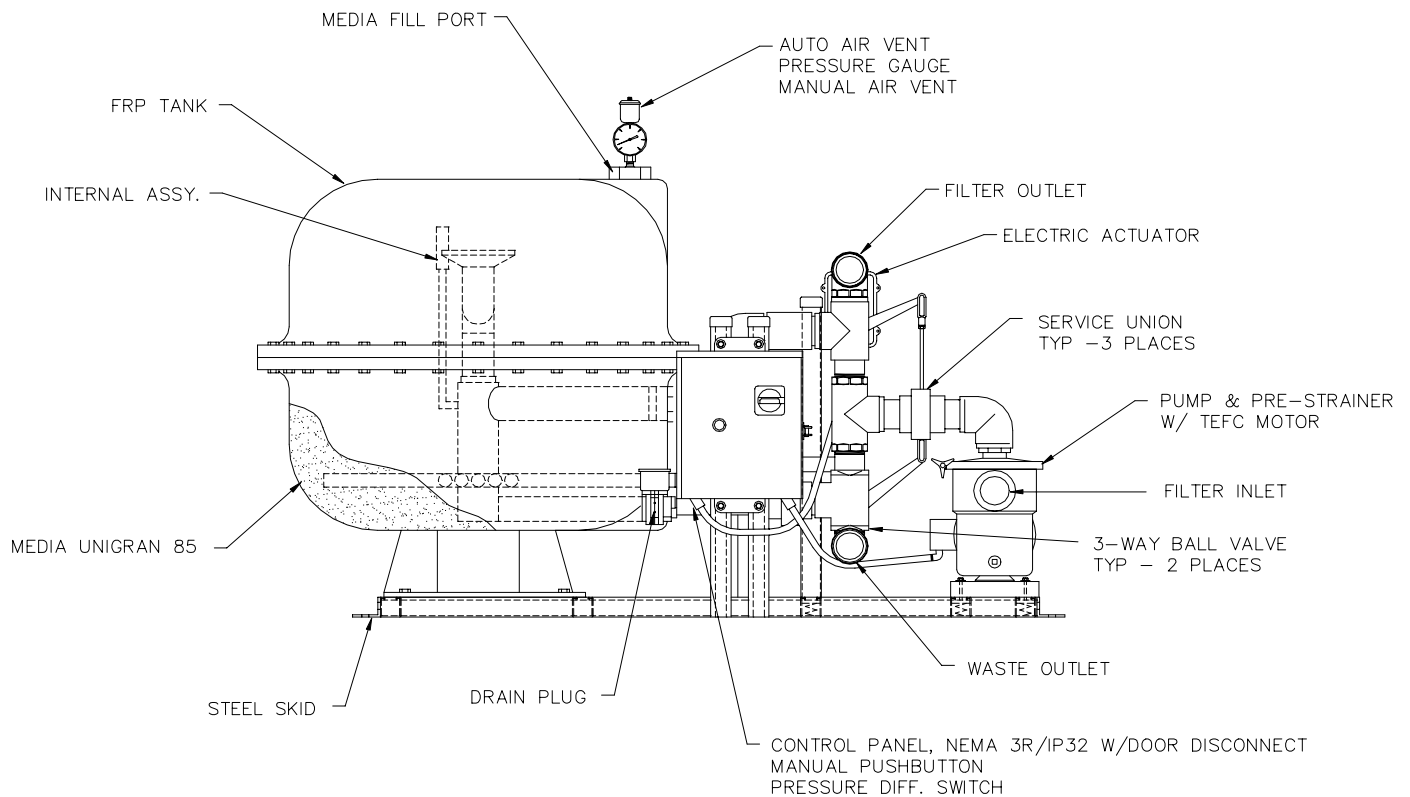

INSTALLATION

All PSF Series Filtration Systems should be rigidly anchored to the floor or support steel by means of anchor bolts. The PSF has holes suitable for 1/2" anchor bolts.

After the unit is installed at a permanent location, the pressure gauge and air relief valves should be installed on the top of the filter tank (some units will have vents already installed). The sand media should be loaded into the filter at this time. Refer to Loading the Filter Media section (Table 4) for a description of how to load the media into the filter tank and the quantity of media necessary for each filter size.

All electrical, mechanical and rotating machinery constitute a potential hazard, particularly for those not familiar with its design, construction and operation. Accordingly, adequate safeguards (including use of protective enclosures when necessary) should be taken with this equipment to safeguard the public from injury and to prevent damage to the equipment, associated systems and the premises.

Piping

The PSF Series Filtration System should be installed as follows. Refer to Table 2 below for connection sizes.

Table 2
Connection Sizes

Model Number	Feed Inlet	Filter Outlet	Waste Drain
PS20F	2.0"	1.5"	1.5"
PS24F	2.0"	1.5"	1.5"
PS30F	2.0"	2.0"	2.0"

1. Connect a feed water line from the system sump or piping to the connection labeled "Inlet" on the pump. If the inlet connection is located above the operating water level of the system sump, install a foot/check valve to prevent loss of suction on the pump.

-
-
2. Connect the return line from the connection labeled “Outlet” to the system sump or piping.
 3. A service valve should be installed on the inlet, outlet, and city water line (if city water is used) to allow servicing of the filter. For units using a backwash source other than the system sump, refer to Table 3 to determine the required backwash flow. Connect this line to the connection labeled “City Water.” The maximum city water backwash supply pressure on the PSF Series Filtration Systems should never exceed the pressure rating of the filter vessel. If public or municipal water is used for backwash, a backflow preventer or check valve is required in the line on all units (check standard local codes).

Table 3
Filter Flow Rates

Model Number	Forward Flow (GPM)	Minimum Backwash Flow (GPM)	Maximum Backwash Flow (GPM)
PS20F	43	33	43
PS24F	63	50	63
PS30F	98	78	98

4. Connect a backwash waste line to the connection labeled “Waste.” This line carries the backwash waste water to the drain. Do not put a valve in the waste line.

*Note: If the drain is not large enough to handle the volume of water during backwash, it may be necessary to use a storage tank to collect the waste water. A valve can be used to regulate the flow from the tank at a suitable rate to the drain. **Never reduce the size of the waste water line.***

5. All interconnecting piping, fittings, valves, or other accessories connected to the filter system (whether supplied by Thermal Care or others) must be independently supported to eliminate stress on piping.

Check with local, county, or other government authorities to ensure compliance with applicable government industry requirement codes.

Note: The media drain plug (1.5") is located at the bottom of the tank.

Actuator Requirements

The PSF Series Filtration Systems utilize electric actuators to control the valve action between the filtration and backwash modes. The electric actuator is designed for 115 volt control.

Loading the Filter Media

The special spherical silica sand media used in all Thermal Care Water Filters is designed to remove up to 90% by volume of the suspended solids 10 microns and larger. The media will ship to the job-site in .5 cu. ft. drums or in 1 cu. ft. bags for easy handling during the media loading process.

Note: Never load media into a dry filter tank, fill tank one-third full with water before loading . Always check filter internals BEFORE loading media.

**Table 4
Media Quantities**

Model Number	Standard 10 Microns Media (Drums)
PS20F	4
PS24F	5
PS30F	8

Wiring

PSF Series Filtration Systems supplied with a pump and automatic backwash controls are provided with the following as standard: NEMA 3R/IP32 control cabinet containing an on/off disconnect switch, motor overload protection, transformer to provide 115v control voltage, backwash timer, 24 hour time clock, pressure differential switch to initiate backwash, valve actuator to reposition valves for backwash, and push button for manual backwash initiation. Units are provided with the requested voltage/phase.

Only units supplied with city or other source backwash are provided with a magnetic motor starter. Units supplied as manual are provided with no motor control of any kind.

Note: Check filter pump nameplate for horsepower and amp draw.

➤ Single Phase Manual Units

1. Install a separate power supply line with circuit breaker protection between the closest branch distribution panel and the pump motor. The full load current for standard models is listed in Table 5 below.

Table 5
Electrical Requirements
Single Phase

Model Number	Pump		Voltage	Full Load Current (Amps)
	HP	KW		
PS20F	1	.75	115/1/60	12
PS20F	1	.75	230/1/60	6
PS24F	2	1.5	115/1/60	20
PS24F	2	1.5	230/1/60	10
PS30F	2	1.5	115/1/60	20
PS30F	2	1.5	230/1/60	10

-
-
2. Install an externally operated switch with fuse protection and door interlock in plain sight of the filter and not more than 50 feet (15 M) away. The thermal overload protection, if required, must be sized for full load amp draw listed on the pump motor nameplate.

➤ **Three Phase Manual Units**

1. Install a separate power supply line with circuit breaker protection between the closest branch distribution panel and the pump motor. The full load current for standard models is listed in Table 6 below

**Table 6
Electrical Requirements
Three Phase**

Model	Pump		Voltage	Full Load Amps
	HP	KW		
PS20F	1	.75	230/3/60	3.6
PS20F	1	.75	460/3/60	1.8
PS24F	2	1.5	230/3/60	5.6
PS24F	2	1.5	460/3/60	2.8
PS30F	2	1.5	230/3/60	5.6
PS30F	2	1.5	460/3/60	2.8

2. Install a service disconnect switch in plain sight of the filter and not more than 50 feet (15 M) away.
3. Install an externally operated manual or magnetic starter with thermal overload and fuse protection. If the unit is to be controlled remotely with a time clock, switch, or other device, a magnetic starter must be used. The thermal overload protection, if required, must be sized for the full load amp draw listed on the pump motor nameplate.

➤ Single and Three Phase Automatic Units

Install a separate power supply line with circuit breaker protection between the closest branch distribution panel and the control box. The full load amps for standard single and three phase units are listed in Tables 5 and 6. The control box contents are prewired and include a service disconnect switch, thermal overload/short circuit protection, a transformer to convert the power supply to single phase, 115 volt for controls. Wire the power supply lines to the disconnect switch. **All incoming power supply lines must connect to the door interlock disconnect.**

OPERATION

PSF Series Filtration Systems are permanent media type units specifically designed to clean industrial and process water. The PSF filters are designed for side stream or in-line applications on non-pressurized systems. The filter tanks on the PSF are equipped for 50/350 psi/kpa maximum.

Water from the system is pumped through the overdrain assembly at the top of the filter tank and distributed evenly over the media. Suspended particles are trapped in the filter media. The filtered water then passes from the vessel through the underdrain assembly at the bottom of the filter and returns to the system.

When the trapped particles cause the pressure differential across the media bed to reach a predetermined pressure of approximately 10 psi over starting gauge pressure, the valves are automatically or manually repositioned and the media is backwashed. The media is backwashed with a rigorous scouring action and the trapped particles are released. The dirty water passes from the filter tank through the overdrain assembly at the top of the vessel and is flushed to the drain. When the media is cleaned after a preset time (3 minutes standard), the valves are again repositioned and the filtration cycle is continued.

During operation, the PSF Series Filtration System should be inspected, cleaned, and lubricated on a regular basis. The required services and recommended frequency (minimum) for each are summarized in the Preventive Maintenance section of this manual.

Water Treatment

Filtration is an effective way of reducing the level of contamination in a system but is only one component of a water treatment program. Dissolved solids originally present in water remaining after evaporation cannot be eliminated by filtration. The concentration of these dissolved solids increases rapidly and can cause scale and corrosion. In addition, airborne impurities and biological contaminants, including Legionella, may be introduced into the recirculating water through the cooling equipment being filtered.

To control all potential contaminants a water treatment program must be employed. In many cases a simple bleed-off in the system may be adequate for control of scale and corrosion. The filter backwash can be used to constitute a portion of the bleed. However, biological contamination can be controlled through the use of biocides and such treatment should be initiated at system start-up and continued regularly thereafter.

For specific recommendations on water treatment contact the Thermal Care Customer Sales Department.

START-UP

24 Hour/7 Day Clock

The 24 hour time clock is used to initiate the 3 minute backwash timer relay at any specified time in the day. The 24 hour backwash clock comes preset from the factory to backwash once every 24 hours of running time. For every nonconsecutive pin pullout in a 24 hour cycle the filter will backwash. Each pin represents 15 minutes of a 24 hour period. The filter can only backwash once every 1/2 hour by time clock. For every pin pullout consecutively, the filter will backwash once and then lock itself out for 15 minutes multiplied by the number of pins pulled out. The 7 day time clock is used to initiate the 3 minute backwash timer relay on any hour at any specific time and day of the week. The 7 day timer will be preset from the factory to backwash once a week. The 7 day timer works the same as the 24 hour clock except each pin represents 2 hours.

Diagram 2
24 Hour/7 Day Clock

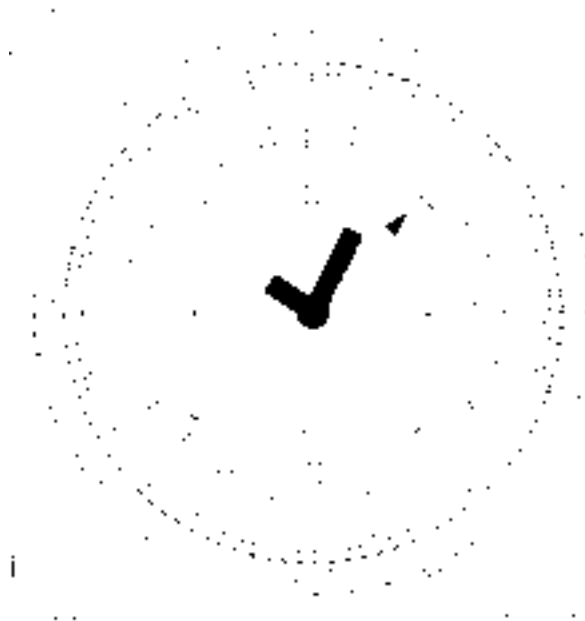

Initial and Seasonal Start-Up

Before initial start-up or after a shutdown period, the PSF Series Filtration System should be thoroughly inspected and cleaned.

Caution

Perform the first five of the following recommendations with the electric power off. Refer to the Safety Precautions in the Preventive Maintenance section regarding the safeguarding of maintenance personnel from biological contaminants prior to initial and seasonal start-up.

1. Loosen the clamp around the pump prestrainer tank lid. Remove the lid, inspect the O-ring seal and lubricate. Clean debris from the pump prestrainer basket. Replace the basket, lid and clamp (now is a good time to prime the pump suction line).
2. Turn the pump and motor shaft by hand to ensure free rotation (if possible).
3. On manual systems only, rotate the valves manually by moving the valve linkage up and down to ensure free operation. Make sure the valves and linkage are in the correct position before start-up.
4. On filters, loosen the access bolts on lid, remove lid and lubricate the bolts as necessary.
5. Inspect the overdrain assembly and media pack. If the media pack is contaminated, remove the foreign material or replace the media. Replace the filter lid.
6. Open manual air relief valve on top of the filter tank. Start the pump motor briefly and check the arrow on the pump volute for proper rotation. Turn the pump motor off. **DO NOT** operate the pump for an extended period of time with the pump

rotating backwards. Have a qualified electrician change leads to correct rotation.

7. With the air relief valve open on top of the filter tank, check the shut-off valves in the filter inlet and outlet water lines to verify that they are open. Make sure the pump is primed. Start the pump and fill filter vessel. Wait for all the air in vessel to be released before closing the manual air relief valve.
8. Check the voltage and current of all leads on the pump motor. The current amp draw should not exceed the nameplate rating.
9. Check the unit for any unusual noise or vibration and contact the Thermal Care Customer Service Department if noise or vibration occurs.
10. Check the unit for any air or water leaks. All air leaks must be found and repaired. Failure to do so could result in poor performance and/or personal injury.
11. Backwash the filter. After backwashing the filter, check the pressure gauge on top of the filter tank and record the clean media operating pressure gauge. The media should be backwashed whenever the pressure drop across the filter reaches approximately 10 PSI over starting pressure.

➤ **After the First Hour of Operation**

1. Open the air relief valve on top of the filter tank. Close the valve after the air has been purged from the system. Excessive air release represents a leak, which must be repaired. Air accumulation in the filter tank can result in an unsafe condition due to excessive pressure within the tank.
2. Check the unit for any unusual noise or vibration and contact the Thermal Care Customer Service Department if noise or vibration occurs.
3. Check unit for any air or water leaks.

PREVENTIVE MAINTENANCE

Cold Weather Operation

PSF Series Filtration Systems that will be exposed to below freezing ambient temperatures require protection to prevent freezing. Installation in a heated indoor space is the best means of preventing the water from freezing in a filter. Where indoor installation is impractical because of filter location or space limitation, supplementary heat must be supplied through the use of electrical heater tape and insulation. The parts of the filter that must be heat traced and insulated are: prestrainer tank, pump, piping, valves, pressure switch tubing, and filter tank. The unit should be drained when it is to be shutdown for any period of time. Refer to the Seasonal Shutdown section below for recommendations.

Seasonal Shutdown

The following services should be performed when the unit is to be shut down for a prolonged time period.

1. Shut off all electrical power.
2. Close the shut-off valves in the filter inlet and outlet water lines. For units using a backwash source other than the system, close the shut-off valve in the line from that source also.
3. Drain all external piping to and from the filter.
4. Open the manual vent valves and open the drain line to the filter tank and piping. After the water has drained, close the drain and vent.
5. On manual units only, rotate the valves manually by moving the linkage up and down to ensure operation without obstruction.
6. Loosen the bolts around the circumference and remove the lid. Lubricate the bolt if necessary. Replace the O-ring if necessary.
7. Inspect the overdrain assembly and media pack. If the media is contaminated, remove the foreign material and replace the media if necessary. Replace the filter lid and secure the bolts.

Maintenance Procedures

The recommendations on frequency of service are minimum, and where operating conditions are severe, the service should be performed more often. For each required service, follow the procedures outlined below. If you need further information that is not covered in this manual, please contact the Thermal Care Customer Service Department.

➤ Pump Prestrainer

Warning: Disconnect all electrical power prior to performing pump maintenance.

The filter prestrainer basket on the pump inlet must be kept clean and free of debris. Shut off the power, close the valves, open air relief valve, remove bolts and lid. Remove the basket and remove foreign material. Replace basket, lubricate O-ring, and tighten clamp (see pump drawing).

➤ Pump

Warning: Disconnect all electrical power prior to performing pump maintenance.

Turn the pump shaft by hand. The impeller should spin freely. If not, remove the prestrainer from the volute and check with a feeler gauge. The clearance between the impeller and volute face is 0.015". Adjust the clearance, if necessary, by loosening the set screws. The impeller and motor shaft are spring loaded and will slide forward/back. Adjust the impeller to proper clearance and tighten set screws. If the impeller remains obstructed, remove the four bolts holding the volute to the motor bracket and impeller, and inspect the volute for foreign material. Reverse the above procedures for replacement.

➤ Backwashing

The media pack must be backwashed whenever the debris buildup increases 10 PSI over the starting pressure gauge reading. Since units with automatic controls perform this function as necessary, a detailed backwash procedure is only given for manual units. However, automatic units can be manually backwashed by pushing the button on the control panel until the valves change position. The valves will then be automatically repositioned after three minutes. **Filters should be backwashed a minimum of once a week.**

For manual control units using a backwash water source other than the system:

1. Shut off the electrical power to the pump motor.
2. Move the handle on the linkage to position the valves in backwash mode.
3. Allow the filter to backwash for approximately three minutes.
4. Move the handle on the linkage to position the valves in the filtration mode.
5. Restart the pump motor.

For manual control units using the system water for backwash:

1. Shut off the electrical power to the pump motor.
2. Move the handle on the linkage to position the valves in the backwash mode.
3. Restart the pump motor.
4. Allow the filter to backwash for approximately three minutes.
5. Shut off the electrical power to the pump motor.
6. Move the handle on the linkage to position the valves in filtration mode.
7. Restart the pump motor.

➤ Filter Tank

The filter tank internal components should be visually inspected annually or whenever backwashing does not reduce the pressure of the filter tank to the starting media gauge pressure. Remove the lid on the top of the tank to inspect the internal components.

Note: Always use care and follow proper shutdown procedures.

Inspect the overdrain assembly for any debris blockage or damage and clean or replace if necessary. Remove and inspect the media. PSF Series Filtration Systems have a 1.5" drain plug located on the bottom of the tank for easy removal of the media and inspection of the underdrain assembly. Over a period of time, foreign matter may become imbedded in the media pack which cannot be backwashed out. Contaminated media should be discarded. Unscrew the underdrain laterals and inspect for blockage or damage. Clean or replace if necessary. Refill tank with the proper amount of uncontaminated media (see Table 6), following media loading instructions .

Safety Precautions

For the protection of authorized service and maintenance personnel, the pump motor associated with this equipment should be installed with a lockable disconnect switch located in close proximity and within sight of the industrial water filter. No service work should be performed on or near the pump motors, without first ensuring that the pump motor has been electrically disconnected and locked out.

The recirculating water system may contain chemicals or biological contaminants which could be harmful if inhaled or ingested. Accordingly, personnel who may be exposed directly to the mists produced by water jets or compressed air (should these be used to clean portions or components of the industrial water filter) should wear half-face respirators with HEPA filter cartridges, NIOSH/MSHA approved number TC-21C-142/TC-21C-182.

Table 7
Operation and Maintenance Schedule

Type of Service	Start-Up	Monthly	Semi-Annually	Shut-down	Annually
Inspect general condition of unit	X	X			
Check and lubricate clamp on strainer lid	X	X		X	X
Clean basket in pre-strainer tank	X	X		X	
Inspect O-ring gasket	X			X	
Check pump shaft for free rotation	X	X	X		
Check operation of valves	X	X		X	
Check, lubricate clamp on filter tank access port	X			X	X
Inspect overdrain assembly and media pack	X			X	X
Check pump motor for proper rotation	X				
Prime pump	X				
Check motor voltage and current	X	X	X		
Check pressure gauge reading (top of filter tank)	X	X			
Check unit for unusual noise or vibration	X	X			
Check unit for leaks	X	X			
Drain filter and piping	X			X	

Diagram 4
Pump Parts Assembly

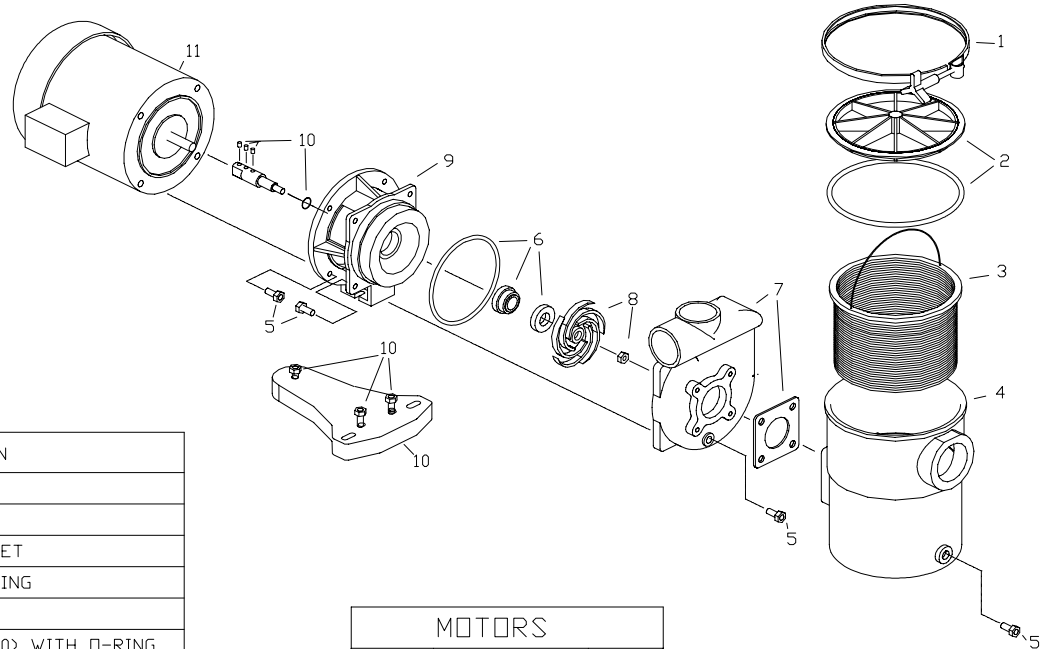

PART #	DESCRIPTION
1	LID CLAMP
2	LID WITH O-RING
3	PRE-FILTER BASKET
4	PRE-FILTER HOUSING
5	BOLT KIT PKG 12
6	SEAL KIT (PS 1000) WITH O-RING
7	BRASS VOLUTE WITH O-RING
8A	IMPELLER WITH NUT, 1/2 HP "5"
8B	IMPELLER WITH NUT, 1 HP "10"
8C	IMPELLER WITH NUT, 1 1/2 HP "15"
8D	IMPELLER WITH NUT, 2 HP "20"
9	PUMP MOTOR MOUNTING BRACKET
10	MOTOR STEP SHAFT WITH O-RING
11	MOTOR (SEE MOTOR SECTION)
12	PUMP BASE PLATE WITH BOLTS

MOTORS		
POWER	VOLTS	PHASE
1	115/230	1
1	230/460	3
1	380	3
1	550/575	3
2	115/230	1
2	230/460	3
2	380	3
2	550/575	3

DIAGRAMS

**Diagram 3
Parts Assembly**

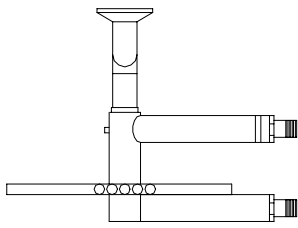

① INTERNAL ASSEMBLY

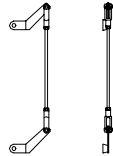

⑩ LINKAGE ASSEMBLY

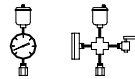

⑤ GAUGE ASSEMBLY

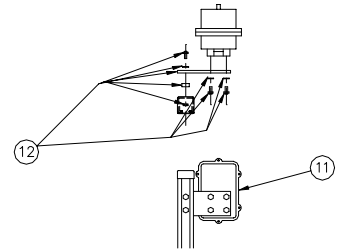

ELECTRIC ACTUATOR ASSEMBLY

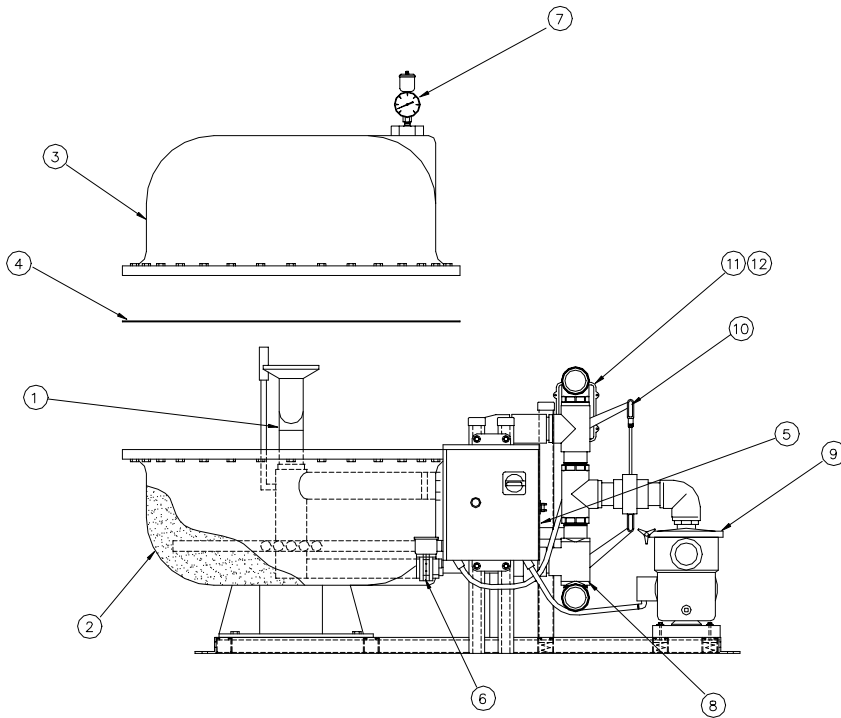

QTY.	DESCRIPTION
1	INTERNALS ASSEMBLY
2	TANK ASSEMBLY (LOWER)
3	TANK ASSEMBLY (UPPER)
4	TANK ASSEMBLY O-RING
5	ELECTRICAL PANEL ASSEMBLY
6	PRESSURE SWITCH
7	GAUGE ASSEMBLY
8	3-WAY BALL VALVE (1 1/2" OR 2")
9	MOTOR/PUMP/STRAINER ASSEMBLY
10	LINKAGE ASSEMBLY
11	ELECTRIC ACTUATOR
12	ELECTRIC ACTUATOR BRACKET KIT

SPA-2074