

Model	Dimensions Inches			Connection Size Inches		Flush Port Inches	Weight Lbs.
	H	W	D	Inlet	Outlet		
SF100	15 7/8	15 3/4	12 1/4	2	2	1 1/2	13

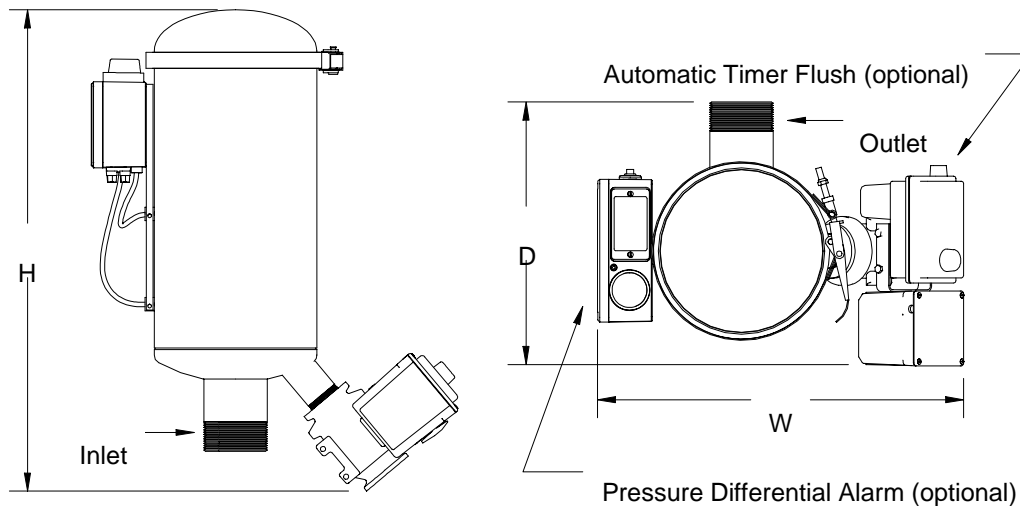

Model	Dimensions Inches			Connection Size Inches		Flush Port Inches	Weight Lbs.
	H	W	D	Inlet	Outlet		
SF200	24 1/2	20 1/4	14 1/2	3	3	1 1/2	27

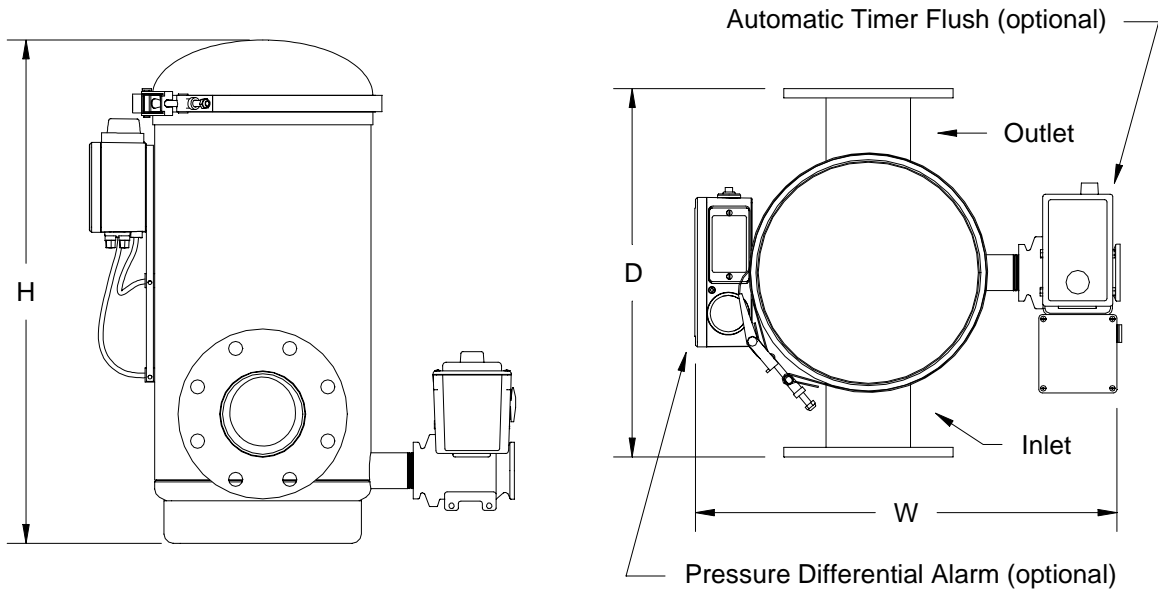

Model	Dimensions Inches			Connection Size Inches		Flush Port Inches	Weight Lbs.
	H	W	D	Inlet	Outlet		
SF350	25 1/2	22 3/4	19 1/2	4	4	1 1/2	60

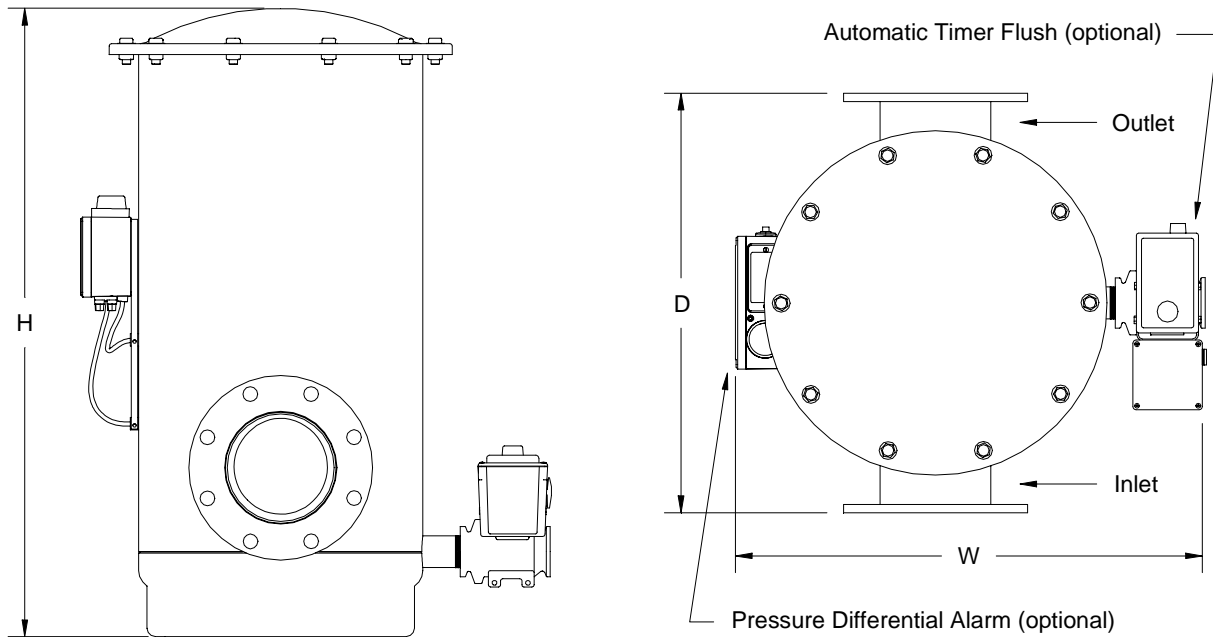

Model	Dimensions Inches			Connection Size Inches		Flush Port Inches	Weight Lbs.
	H	W	D	Inlet	Outlet		
SF750	37 1/2	28 1/4	25	6	6	1 1/2	125
SF1300	48 1/4	34 1/4	31 1/2	8	8	1 1/2	230
SF2000	59 1/2	41 1/4	39 3/4	10	10	1 1/2	400



Form 6-205.1

7720 North Lehigh Avenue  
 Niles, Illinois 60714-3491  
 Tel: (847) 966-2260  
 Toll Free: (888) 828-7387  
 Fax: (847) 966-9358

Email: [info@thermalcare.com](mailto:info@thermalcare.com)  
 Website: [www.thermalcare.com](http://www.thermalcare.com)

*Manufacturer reserves the right to change specifications or design without notice or obligation. Thermal Care is a registered trademark of MFRI, Inc.*